

ALUMINUM HANDRAIL

Safety Every Step of the Way

Handrail 72" and longer have center post.

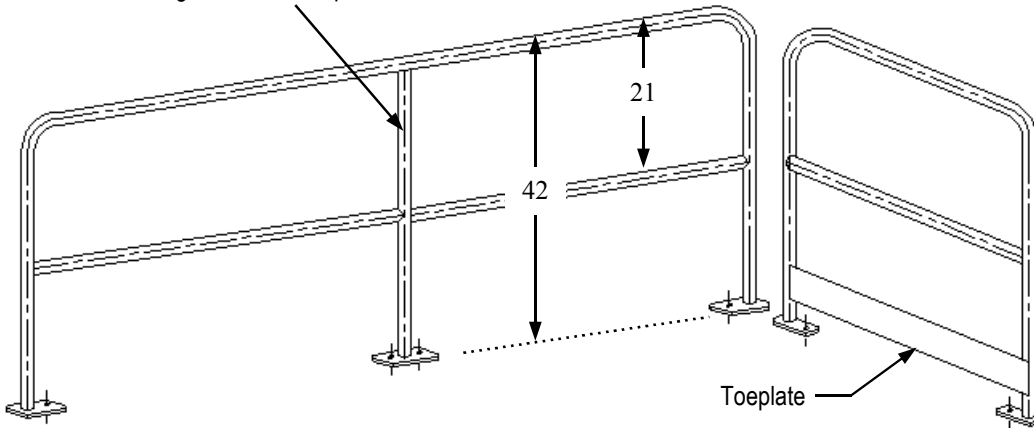

- Aluminum handrail does not rust and is virtually maintenance free.
- Light and easy to install.
- 9/16" mounting holes in foot pads.
- Available with or without toeplate.
- Many different stock lengths from which to choose.
- Handrail is 1 1/2" pipe.
- Customer responsible for suitable anchoring and hardware.

All-Welded Aluminum Handrails:

Provides handrail protection to increase safety.

Quick installation.

Handrail is OSHA compliant.

Ships in 2—3 weeks

Please ask about our *FastTrak* program for customized handrails.

Without Toeplate

| | |
|--------|----------|
| HRA101 | 24" LONG |
| HRA102 | 36" LONG |
| HRA103 | 48" LONG |
| HRA104 | 60" LONG |
| HRA105 | 72" LONG |
| HRA106 | 84" LONG |
| HRA107 | 96" LONG |



With Toeplate

| | |
|--------|----------|
| HTA101 | 24" LONG |
| HTA102 | 36" LONG |
| HTA103 | 48" LONG |
| HTA104 | 60" LONG |
| HTA105 | 72" LONG |
| HTA106 | 84" LONG |
| HTA107 | 96" LONG |



Ask about our other products: Firm-Grip™ Gratings ♦ Industrial Work Platforms ♦ Truck and Trailer Accessories.

Bustin
Since 1928

BUSTIN INDUSTRIAL PRODUCTS, Inc.

www.bustin-usa.com
info@bustin-usa.com

Tollfree: (800) 933-5166
Phone: (570) 424-6500
FAX: (570) 424-6453

ISO 9001 REGISTERED COMPANY